

**Multifunctional room sensors and measuring transducers,
 for humidity, temperature, air quality (VOC) and CO₂ content,
 calibratable, with active/switching output**

The maintenance-free microprocessor-controlled room sensor **AERASGARD® RTM-CO₂-SD** with automatic calibration is used for detecting the CO₂ content of the air within a range of 0...2000 ppm and the temperature within a range of 0...+50°C. The measured values are converted into standard signals of 0-10 V.

The maintenance-free microprocessor-controlled room sensor **AERASGARD® RFTM-LQ-CO₂-W** and **RCO₂-W/RLQ-CO₂-W** with automatic and manual calibration is used for detecting the overall room climate. It measures CO₂ within a range of 0...2000 ppm or 0...5000 ppm, air quality (VOC) in one of three sensitivity levels that can be selected LOW / MEDIUM (default) / HIGH, temperature within a range of 0...+50°C as well as relative humidity of 0...100% r.H. The measured values are converted into standard signals of 0-10 V oder 4...20 mA (selectable via DIP switches). As an option, the measured values can be shown continuously in the illuminated display.

Elegant enclosure made of plastic, with snap-on lid, base with 4-hole attachment, for installation on vertically or horizontally installed in-wall flush boxes, with predetermined breaking point for on-wall cable entry.

The relative humidity (% r.H.) quotient of water vapour partial pressure divided by the saturation vapour pressure at the respective gas temperature. A digital, long-term stable sensor used as measuring element for relative air humidity and temperature guarantees exact measurement results. The air quality is determined based on a (VOC) gas mixture sensor. The CO₂ content of the air is measured using an optical NDIR sensor (non-dispersive infra-red technology).

For more information, see the start of the chapter!

TECHNICAL DATA

Voltage supply:	24 V AC / DC (± 10%)
Power consumption:	RCO₂-W / RTM-CO₂-SD: < 1.5 W / 24 V DC typical; < 2.9 VA / 24 V AC typical; peak current 200 mA RLQ-CO₂-W / RFTM-LQ-CO₂-W: < 4.4 W / 24 V DC typical; < 6.4 VA / 24 V AC typical; peak current 200 mA
Outputs:	RTM-CO₂-SD 0-10 V (fixed) Rxx-CO₂-W 0-10 V or 4...20 mA (selectable via DIP switches, selected variant applies for all outputs), working resistance < 800 Ω
Relay output:	RTM-CO₂-SD without changeover contact Rxx-CO₂-W with potential-free changeover contact 24 V (assignment selectable via DIP switches)

HUMIDITY

Sensors:	digital humidity sensor with integrated temperature sensor, low hysteresis, high long-term stability
Measuring range, humidity:	0...100% r.H.
Operating range, humidity:	0...95% r.H. (without dew formation)
Deviation, humidity:	typically ± 2.0% (20...80% r.H.) at +25 °C, otherwise ± 3.0%
Output, humidity:	0-10 V or 4...20 mA (selectable via DIP switches)

TEMPERATURE

Measuring range, temperature:	0...+50 °C
Operating range, temperature:	0...+50 °C
Temperature deviation:	± 0.2 K at +25 °C
Output, temperature:	RTM-CO₂-SD 0-10 V (fixed) Rxx-CO₂-W 0-10 V or 4...20 mA (selectable via DIP switches)

AIR QUALITY (VOC)

Sensor, VOC:	VOC sensor (metal oxide) with automatic calibration (VOC = volatile organic compounds)
Measuring range, VOC:	0...100% air quality; referred to calibrating gas; multi-range switching (selectable via DIP switches) VOC sensitivity low, medium, high
Output, VOC:	0-10 V (0 V = clean air, 10 V = polluted air) or 4...20 mA (selectable via DIP switches, switchpoint can be adjusted from 0...100% of the output signal)
Measuring accuracy, VOC:	± 20% of final value (referred to calibrating gas)
Service life:	> 60 months (under normal load conditions)

CARBON DIOXIDE (CO₂)

Sensor, CO ₂ :	optical NDIR sensor (non-dispersive infra-red technology), RTM-CO₂-SD with automatic calibration Rxx-CO₂-W with automatic and manual calibration
Measuring range, CO ₂ :	RTM-CO₂-SD 0...2000 ppm (fixed) Rxx-CO₂-W 0...2000 ppm or 0...5000 ppm (selectable via DIP switches)
Output, CO ₂ :	RTM-CO₂-SD 0-10 V (fixed) Rxx-CO₂-W 0-10 V or 4...20 mA (selectable via DIP switches)
Measuring accuracy, CO ₂ :	± 30 ppm ± 3% of measured value
Temperature dependence, CO ₂ :	± 5 ppm / °C or ± 0.5% of measured value / °C (whichever is higher)

(continued on next page!)



NEW

S+S REGELTECHNIK

AERASGARD® RCO₂-W / RLQ-CO₂-W AERASGARD® RFTM-(LQ)-CO₂-W / RTM-CO₂-SD

Multifunctional room sensors and measuring transducers,
for humidity, temperature, air quality (VOC) and CO₂ content,
calibratable, with active/switching output



Dimensional drawing

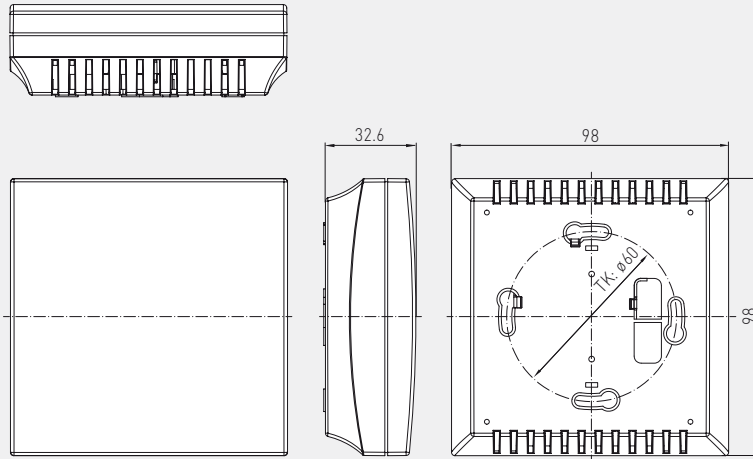

RCO₂-W with display
RLQ-CO₂-W
RFTM-LQ-CO₂-W
RTM-CO₂-SD

RLQ-CO₂-W
RFTM-LQ-CO₂-W
RTM-CO₂-SD



RCO₂-W
RLQ-CO₂-W
RFTM-LQ-CO₂-W
without display



TECHNICAL DATA (continued)

Pressure dependence:	±0.13% / mm Hg
Long-term stability:	< 2% in 15 years
Gas exchange:	by diffusion
Ambient temperature:	0...+ 50 °C
Warm up time:	approx. 1 hour
Response time:	< 2 minutes
Electrical connection:	0.14 - 1.5 mm ² , via screw terminals
Enclosure:	plastic, material ABS, colour pure white (similar to RAL 9010)
Dimensions:	98 x 98 x 33 mm (Baldu2)
Installation:	wall mounting or on in-wall flush box, Ø55 mm, base with 4 holes, for attachment to vertically or horizontally installed in-wall flush boxes for rear cable entry, with predetermined breaking point for cable entry from top /bottom in case of plain on-wall installation
Protection class:	III (according to EN 60730)
Protection type:	IP 30 (according to EN 60529)
Standards:	CE conformity, electromagnetic compatibility according to EN 61326, EMC Directive 2014 / 30 / EU, Low Voltage Directive 2014 / 35 / EU
Optional:	display with illumination , two line, cutout approx. 36 x 15 mm (W x H), for displaying actual humidity, actual temperature, air quality and/or the actual CO ₂ content

AERASGARD® RCO₂-W / RLQ-CO₂-W
AERASGARD® RFTM-(LQ)-CO₂-W / RTM-CO₂-SD

NEW



S+S REGELTECHNIK

Multifunctional room sensors and measuring transducers,
 for humidity, temperature, air quality (VOC) and CO₂ content,
 calibratable, with active/switching output

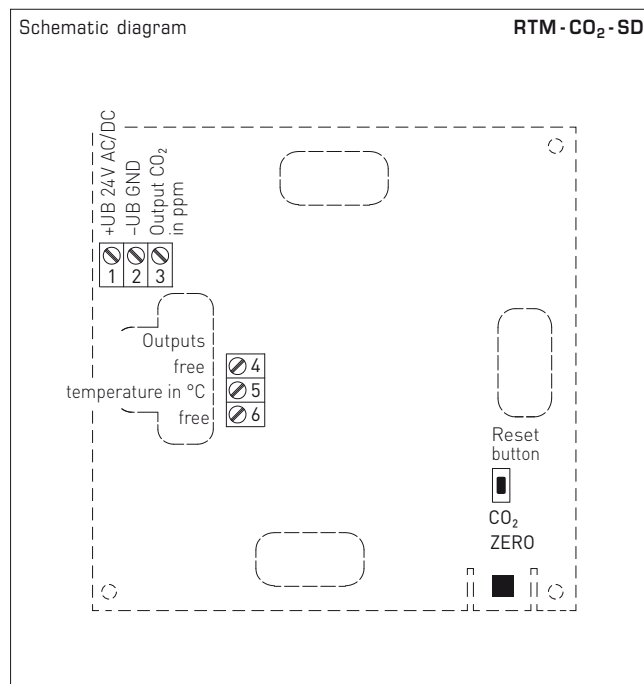
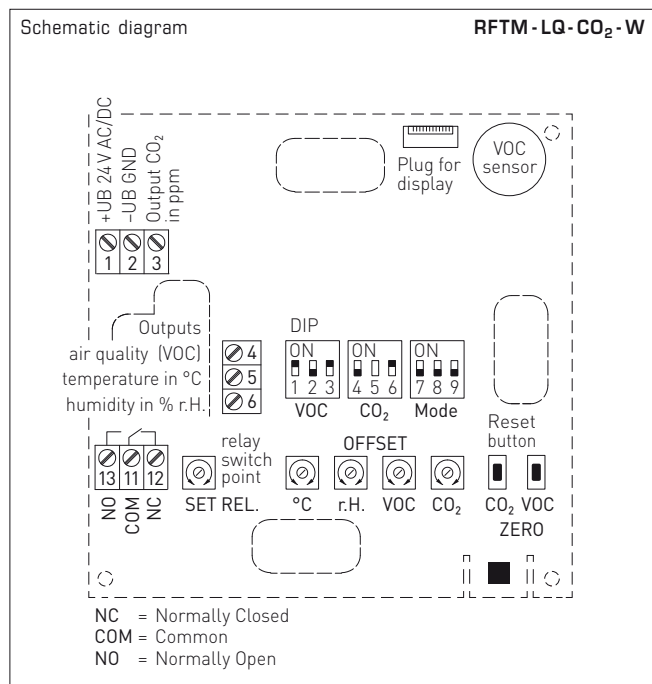

DIP switches	RFTM-LQ-CO₂-W	
VOC sensitivity	DIP 1	DIP 2
LOW	OFF	OFF
MEDIUM (default)	ON	OFF
HIGH	OFF	ON
VOC automatic zero point	DIP 3	
deactivated	OFF	
activated (default)	ON	
CO₂ content	DIP 4	
0...2000 ppm (default)	OFF	
0...5000 ppm	ON	
CO₂ automatic zero point	DIP 6	
deactivated	OFF	
activated (default)	ON	
Relay assignment	DIP 7	DIP 8
CO ₂ (default): 600...1900 ppm / 900...4700 ppm	OFF	OFF
VOC: 10...95 %	ON	OFF
Temperature: +5...+48 °C	OFF	ON
Humidity: 10...95% r.H.	ON	ON
Output	DIP 9	
Voltage 0-10V (default)	OFF	
Current 4...20 mA	ON	
Note: DIP 5 is not assigned!		

RFTM-LQ-CO₂-W
 (Balduur 2)





NEW

S+S REGELTECHNIK

AERASGARD® RCO₂-W / RLQ-CO₂-W
AERASGARD® RFTM-(LQ)-CO₂-W / RTM-CO₂-SD

Multifunctional room sensors and measuring transducers,
 for humidity, temperature, air quality (VOC) and CO₂ content,
 calibratable, with active/switching output

Humidity table

MR: 0...100% r.H.

% r.H.	U _A in V	I _A in mA
0	0	4.0
5	0.5	4.8
10	1.0	5.6
15	1.5	6.4
20	2.0	7.2
25	2.5	8.0
30	3.0	8.8
35	3.5	9.6
40	4.0	10.4
45	4.5	11.2
Continued at the right ...		

% r.H.	U _A in V	I _A in mA
50	5.0	12.0
55	5.5	12.8
60	6.0	13.6
65	6.5	14.4
70	7.0	15.2
75	7.5	16.0
80	8.0	16.8
85	8.5	17.6
90	9.0	18.4
95	9.5	19.2
100	10.0	20.0

Temperature table

MR: 0...+50 °C

°C	U _A in V	I _A in mA
0	0	4.0
5	1.0	5.6
10	2.0	7.2
15	3.0	8.8
20	4.0	10.4
25	5.0	12.0
30	6.0	13.6
35	7.0	15.2
40	8.0	16.8
45	9.0	18.4
50	10.0	20.0

AERASGARD® RTM-CO ₂ -SD	Room temperature and CO ₂ sensor, <i>Standard</i>
AERASGARD® RCO ₂ -W	Room CO ₂ sensor, <i>Premium</i>
AERASGARD® RLQ-CO ₂ -W	Room air quality (VOC) and CO ₂ sensor, <i>Premium</i>
AERASGARD® RFTM-CO ₂ -W	Multifunctional room sensor for humidity, temperature and CO ₂ content, <i>Deluxe</i>
AERASGARD® RFTM-LQ-CO ₂ -W	Multifunctional room sensor for humidity, temperature, CO ₂ content and air quality (VOC), <i>Deluxe</i>

Type / WG02	Measuring Range			VOC	Equipment Display	Item No. (Baldur 2)	Price
	Humidity	Temperature	CO ₂				
RTM-CO₂-SD			(fixed)				
RTM-CO2-SD-U	-	0...+50 °C	0...2000 ppm	-	-	1501-61B2-1001-200	202,98 €
RCO₂-W			(switchable)				
RCO2-W (without Display)	-	-	0...2000 / 5000 ppm	-	W	see RCO ₂ -W / RCO ₂ -SD	
RCO2-W-DISPLAY	-	-	0...2000 / 5000 ppm	-	W ■	1501-61B0-7321-200	261,33 €
RLQ-CO₂-W			(switchable)				
RLQ-CO2-W	-	-	0...2000 / 5000 ppm	0...100%	W	1501-61B1-7301-200	326,40 €
RLQ-CO2-W DISPLAY	-	-	0...2000 / 5000 ppm	0...100%	W ■	1501-61B1-7321-200	368,43 €
RFTM-CO₂-W			(switchable)				
RFTM-CO2-W	0...100% r.H.	0...+50 °C	0...2000 / 5000 ppm	-	W	1501-61B6-7301-200	295,80 €
RFTM-CO2-W DISPLAY	0...100% r.H.	0...+50 °C	0...2000 / 5000 ppm	-	W ■	1501-61B6-7321-200	337,83 €
RFTM-LQ-CO₂-W			(switchable)				
RFTM-LQ-CO2-W	0...100% r.H.	0...+50 °C	0...2000 / 5000 ppm	0...100%	W	1501-61B8-7301-200	357,00 €
RFTM-LQ-CO2-W DISPLAY	0...100% r.H.	0...+50 °C	0...2000 / 5000 ppm	0...100%	W ■	1501-61B8-7321-200	399,03 €
Outputs:	0-10V or 4...20mA (selectable via DIP switches, selected variant applies for all outputs) – <i>Standard</i> room sensor RTM-CO₂-SD with fixed output 0-10V!						
Equipment:	W = changeover contact – <i>Standard</i> room sensor RTM-CO₂-SD without changeover contact!						
Note:	This unit must not be used as safety-relevant device!						